

DCX to CLUB IQ FOR SHUNT (SEPARATELY-EXCITED) WOUND MOTORS (DCX products)

PART NO. Doc100-054
3/15/2007

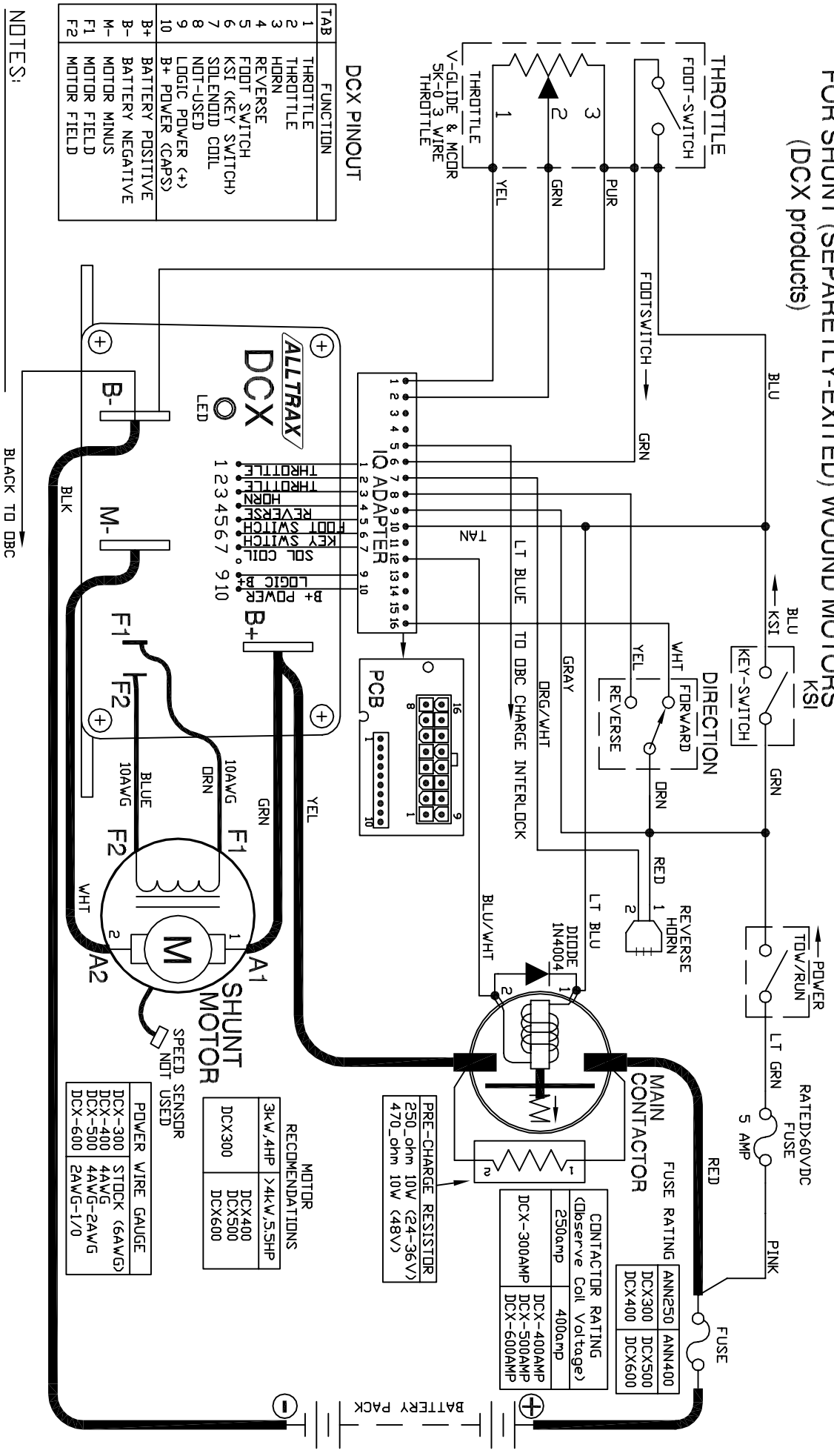

NOTES:

- * FUSES REQUIRED FOR ALL INSTALLATIONS
- * DIODE REQUIRED ACROSS COILS / RELAYS
- * TOW/RUN SWITCH PREVENTS REGEN WHILE TOWING
- > ASSUMES FOOTSWITCH IS OPEN WHEN THROTTLE OFF
- > ALLTRAX RESERVES THE RIGHT TO CHANGE DOCUMENTATION WITHOUT NOTICE
- > ALLTRAX MAKES NO WARRANTY AS TO THE ACCURACY, SUFFICIENCY, OR SUITABILITY OF ANY TECHNICAL OR OTHER INFORMATION PROVIDED
- > SEE OPERATORS MANUAL FOR MORE INFORMATION

DO NOT SCALE DRAWING

REVISIONS

REV.	ECO.	DATE	APVD
A	090407	090407	TT

DWG SCALE: NTS

DRAWN	R. CSUK	031507
ENGR	D.Crockett	121406

1111 Cheney Creek Rd
Granta Pass, OR 97527
PHONE:(541) 478-3565

DCX to Club Car IQ WITH
Separate Excited Motors - Wiring Dia

PROPRIETARY
THIS TECH DRAWING IS THE PROPERTY
OF ALLTRAX. IT IS NOT TO BE
REPRODUCED, COPIED, OR
DISCLOSED IN ANY MANNER
WITHOUT THE WRITTEN
PERMISSION OF ALLTRAX INC.

SIZE DOCUMENT NO. Doc100-054

FILE: DMW-DCX-CLUBCAR-IQ-WIRE-DRAWING SHEET 1 of 1